

MIL-N-1645/1~1000mW

LD PUMPED ALL-SOLID-STATE INFRARED LASER

All solid state 1645nm infrared laser is in the eye-safe spectral range and made features of good beam quality which is widely used for long-distance telemetry and ranging, laser radars, and designation , etc.



SPECIFICATIONS

Wavelength (nm)	1645±1
Output power (mW)	>1,5,10.....1000
Operating mode	CW
Power stability (rms, over 4 hours)	<5%
Warm-up time (minutes)	<10
M ² factor	<2
Beam divergence, full angle (mrad)	<3
Beam diameter at the aperture (mm)	<3
Beam height from base plate (mm)	17
Operating temperature (°C)	10~30
Power supply (90-264VAC)	FC-W-B
Expected lifetime (hours)	10000
Warranty period	1 year



MxL-N-1645

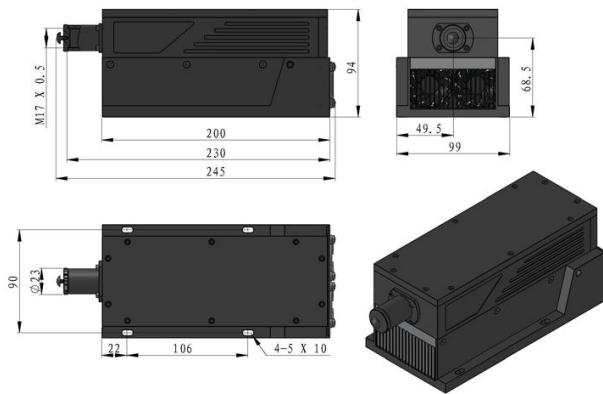

245(L)×99(W) ×94(H) mm³, 2.6 kg

FC-W-B

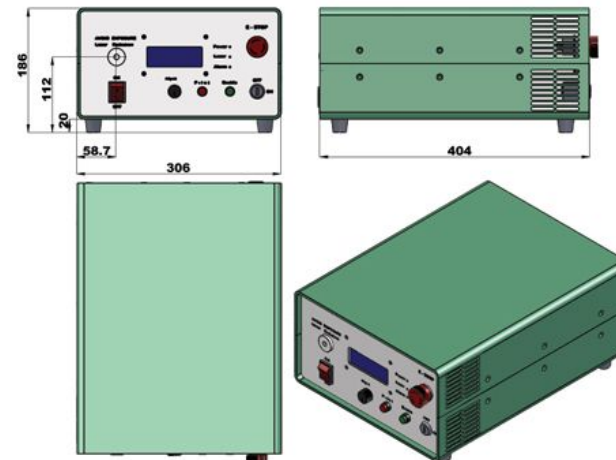

404 (L) ×306(W) ×186(H) mm³, 5.2 kg