

PGL-II-E -532/10~100mW

LD PUMPED ALL-SOLID-STATE GREEN LASER

All solid state 532 green laser is made features of ultra compact, long lifetime, low cost and high stability, which is widely used in collimation, laser medical treatment, scientific experiment, optical instrument, etc.



SPECIFICATIONS

Wavelength (nm)	532±1
Output power (mW)	>10, 20, ...,100
Transverse mode	TEM ₀₀
M ² factor	<1.2
Operating mode	CW
Power stability (rms, over 4 hours)	<1%, <3%, <5%, <10%
Warm-up time (minutes)	<10
Beam divergence, full angle (mrad)	<1.2(1.8~2.0 optional)
Beam diameter at the aperture (mm)	~1.5
Beam height from base plate (mm)	22
Operating temperature (°C)	10~35
Power supply (SVDC)	PSU-II-E-OEM
Modulation option	TTL on/off, 1Hz-1KHz, 1KHz-10KHz, 10KHz-30KHz; and Analog modulation option
Expected lifetime (hours)	5000
Warranty period	1 year

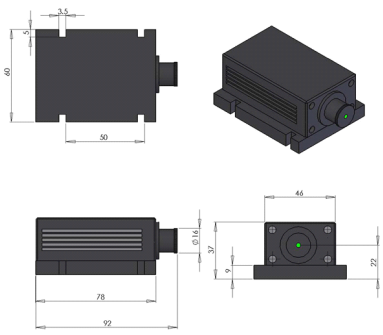
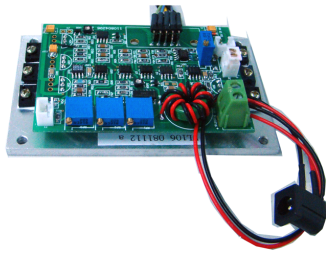

PGL-II-E-532	Dimensions	PSU-II-E-OEM	Dimensions
 <p>92 (L) ×60(W) ×37(H) mm³, 0.3 kg</p>		 <p>88 (L) ×62(W) ×25.5(H) mm³, 0.15 kg</p>	